

Dimensions

Model	S-1	S-2	S-3	S-4	S-5	S-6	S-7	S-8	S-9	S-10	S-11	S-12	S-13	Serration Pitch	Matching Chuck	3 Jaw Weight (kg)
SJ04	52	23	23	10	5	10	14	28	9	14	13	M8	3	1.5×60°	3H-04, 3P-04	0.5
SJ05	62	25	30	10	5	10	14	38	9	14	18	M8	3.5	1.5×60°	3H-05, 3L-205, 3P-05, 3M-05	0.8
SJ06	73	31	36	12	5	15	20	38	11	17	24	M10	14	1.5×60°	3H-206, 3L-206, 3P-06, 3M-06	1.5
SJ08	95	35	37	14	5	24	25	46	13	19	22	M12	16	1.5×60°	3H-208, 3L-208, 3P-08, 3M-08	2.4
SJ10	110	40	42	16	5	30	30	50	13	19	27	M12	18	1.5×60°	3H-10, 3L-210, 3P-10, 3M-10	3.7
SJ12H	130	50	50	21	5	40	30	60	18	26	33	M16	23	1.5×60°	3H-212, 3L-212, 3V-12, 3P-12, 3M-12	6.3
SJ12P	130	50	50	18	5	40	30	60	16	23	33	M14	23	1.5×60°	3P-12	6.5
SJ15H	165	62	62	22	8	37	43	85	21	32	38	M20	-	1.5×60°	3H-15, 3H-18	12.6
SJ15P	165	62	62	25.5	8	37	43	85	21	32	38	M20	-	1.5×60°	3H-15, 3H-18, 3L-15, 3P-15, 3P-18, 3V-15, 3V-18	12.5
SJ21	180	65	70	25	9	40	60	80	21	32	45	M20	-	3.0×60°	3H-21, 3H-24, 3P-221, 3P-224, 3V-21, 3V-24, 3V-32	15.8

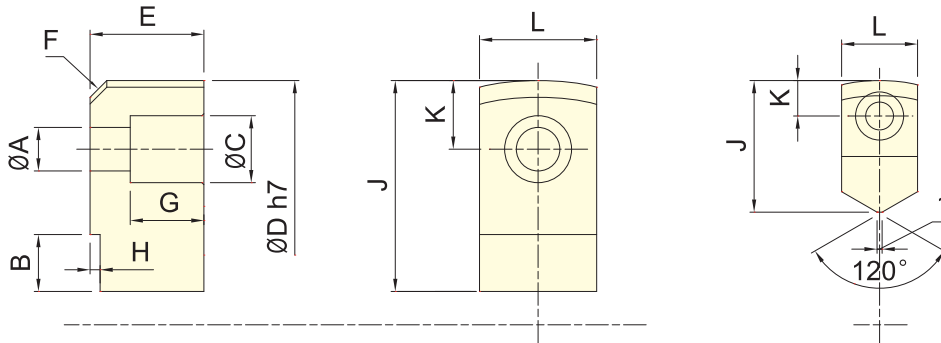

for 3U-203

* Subject to technical changes.

Dimensions

Model	A	B	C	D	E	F	G	H	J	K	L
3U-203	5.5	11	9.5	66	12	C3	7	3	26	7	15
3U-204	6.6	11	11	84	17	C4	11	3	32	9.5	20
3U-205	9	13.5	14	108	20	C4	12	3	41.5	13	24
3U-206	11	15	17	129	30	C6	20	3	50	17	30
3U-208	13	17	20	156	34	C6	22	3	63	20.5	35
3U-210	15	20	22	187	39	C6	24	4	74	23	40
3U-212	15	18	22	234	44	C6	29	4	72	23	40